



Saturn Block

Technical Features & Options

- Interchangeability of couplings: equipped with ISO 16028 couplings size 1/2, 5/8, and 3/4 inch. Drain line is ISO 16028 size 3/8 or 1/2 inch male
- Couplings type: flat face
- Connection system: push to connect
- Disconnection system: pulling back the sleeve of the female coupling
- Connection with residual pressure: after draining the pressure with the knob
- Disconnection with residual pressure: after draining the pressure with the knob
- Threads available: 3/4 JIC for pressure lines, 3/8 SAE for drain line
- Threads on request: metric DIN, ORFS, SAE, BSP and others
- Surface treatment: CrIII zinc plated
- Seals: standard in NBR (Nitrile), POM
- Anti-extrusion rings: PTFE

Main Applications

- Skid steers
- Excavators
- Mobile construction equipment
- Mini-excavators

Features & Options

- User-friendly relief system allows for easy connection/disconnection with residual pressure
- Drain the residual pressure before connection and disconnection, allowing the connection without pressure and without effort in order to reduce injury risk
- Equipped with ISO 16028 interchangeable size 1/2 male & female parts flat face. Drain line in the middle is 3/8 size male.
- Direct replacement for other connect under pressure systems
- Low cost field replacement couplers
- Modular design allows for optional size 5/8 or 3/4 body male & female for high flow circuits and 1/2 drain line



DESCRIPTION	SIZE	MAX. OPERATING PRESSURE COUPLED		MAX. RESIDUAL PRESSURE DURING CONNECTION		SPILLAGE*
		MPa	psi	MPa	psi	ml
SATURN BLOCK 13	1/2	35	5075	25	3625	0.020
SATURN BLOCK 15	5/8	35	5075	25	3625	0.026
SATURN BLOCK 17	3/4	35	5075	25	3625	0.032

* SPILLAGE IS AN INDICATIVE VALUE OF THE FLUID LOSS PER COUPLE-UNCUPLE CYCLE.

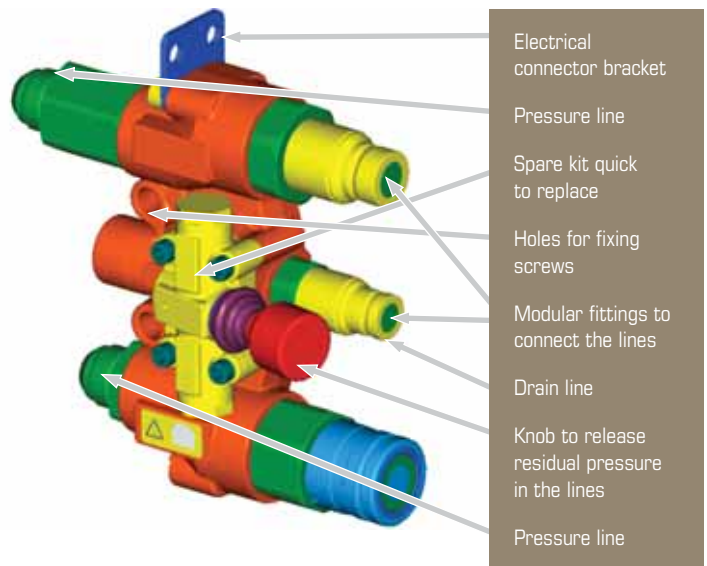
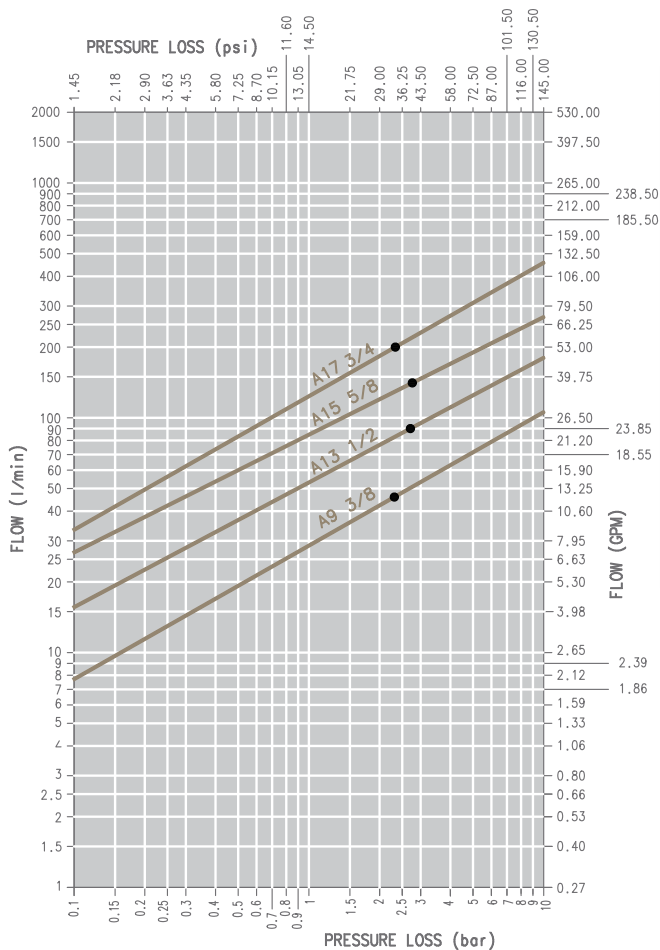

Saturn Block: Size Diagram

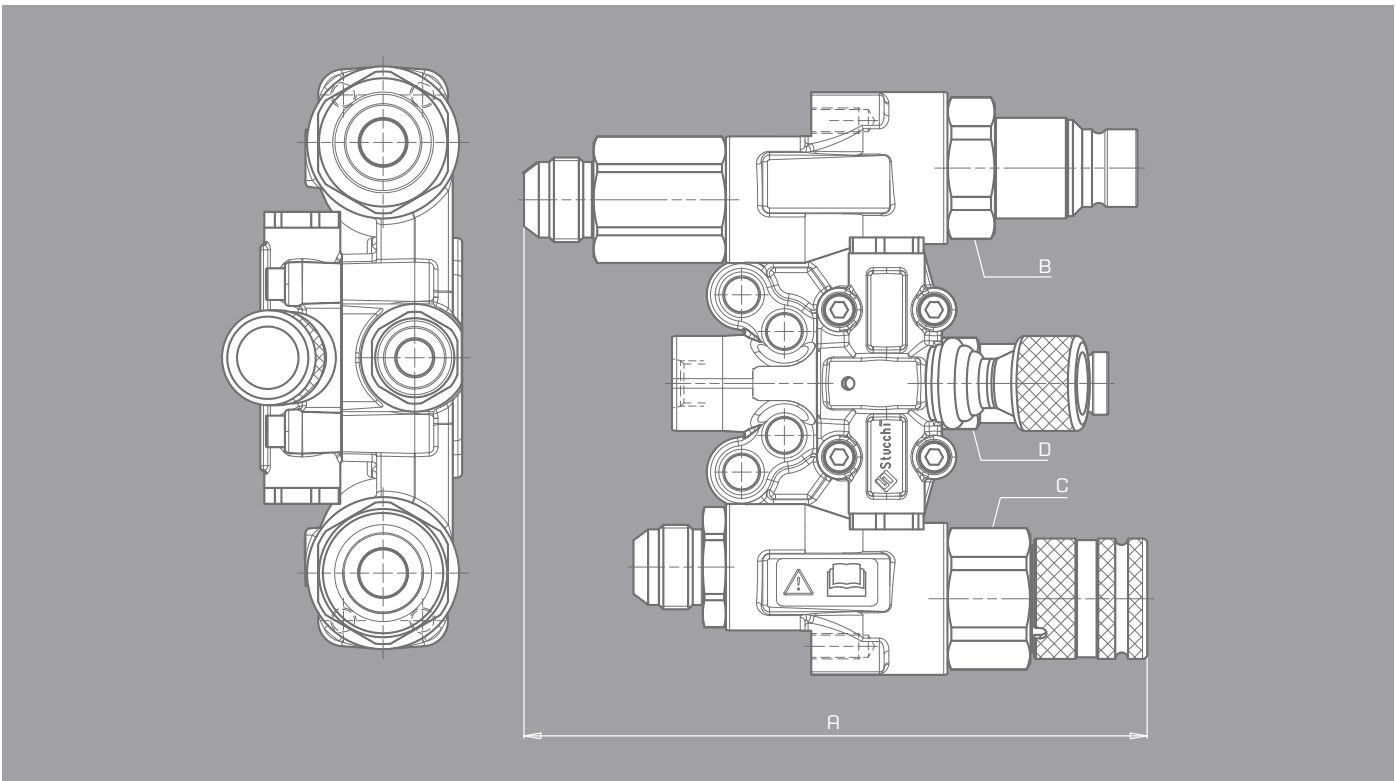

DESCRIPTION	SATURN BLOCK CODE	BODY SIZE	UNIT	A	B	C	D	UP	DRAIN	DOWN	UNIT	WEIGHT
SATURN BLOCK 13	808800102	1/2	mm	196.8	41	41	27	DN 12.5	DN 10	DN 12.5	Kg	4.312
			inch	7.75	1.61	1.61	1.06	1/2	3/8	1/2	lb	9.506
SATURN BLOCK 15	808800103	5/8	mm	203.7	41	41	27	DN 16	DN 10	DN 16	Kg	4.437
			inch	8.02	1.61	1.61	1.06	5/8	3/8	5/8	lb	9.782
SATURN BLOCK 17	808800104	3/4	mm	224	46	46	32	DN 19	DN 12.5	DN 19	Kg	5.052
			inch	8.82	1.81	1.81	1.26	3/4	1/2	3/4	lb	11.138

Saturn Block: Order Codes

DESCRIPTION	ORDER CODE	BODY SIZE: COUPLER & NIPPLE	DRAIN LINE SIZE
SATURN BLOCK 13	808800102	1/2	3/8
SATURN BLOCK 15	808800103	5/8	3/8
SATURN BLOCK 17	808800104	3/4	1/2
SATURN BLOCK 17	808800105	3/4	3/8

* USE "R" SUFFIX TO REVERSE POSITIONS OF COUPLER & NIPPLE IN THE SATURN BLOCK



Saturn Block: How to Relieve Pressure

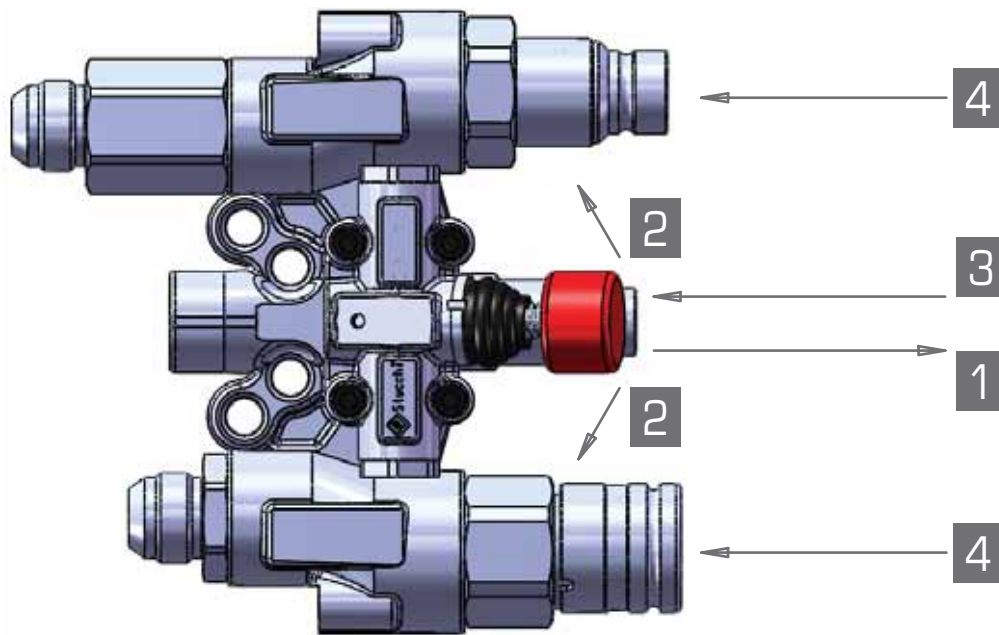

How to Operate the Pressure Relief Valve on the Saturn Block

1. Pull red knob on pressure relief valve out
2. Pull red knob up/down to relieve pressure
3. Release red knob, allowing it return to starting position
4. Insert coupler/nipple into the Saturn Block





Saturn Block: Replacment Parts List

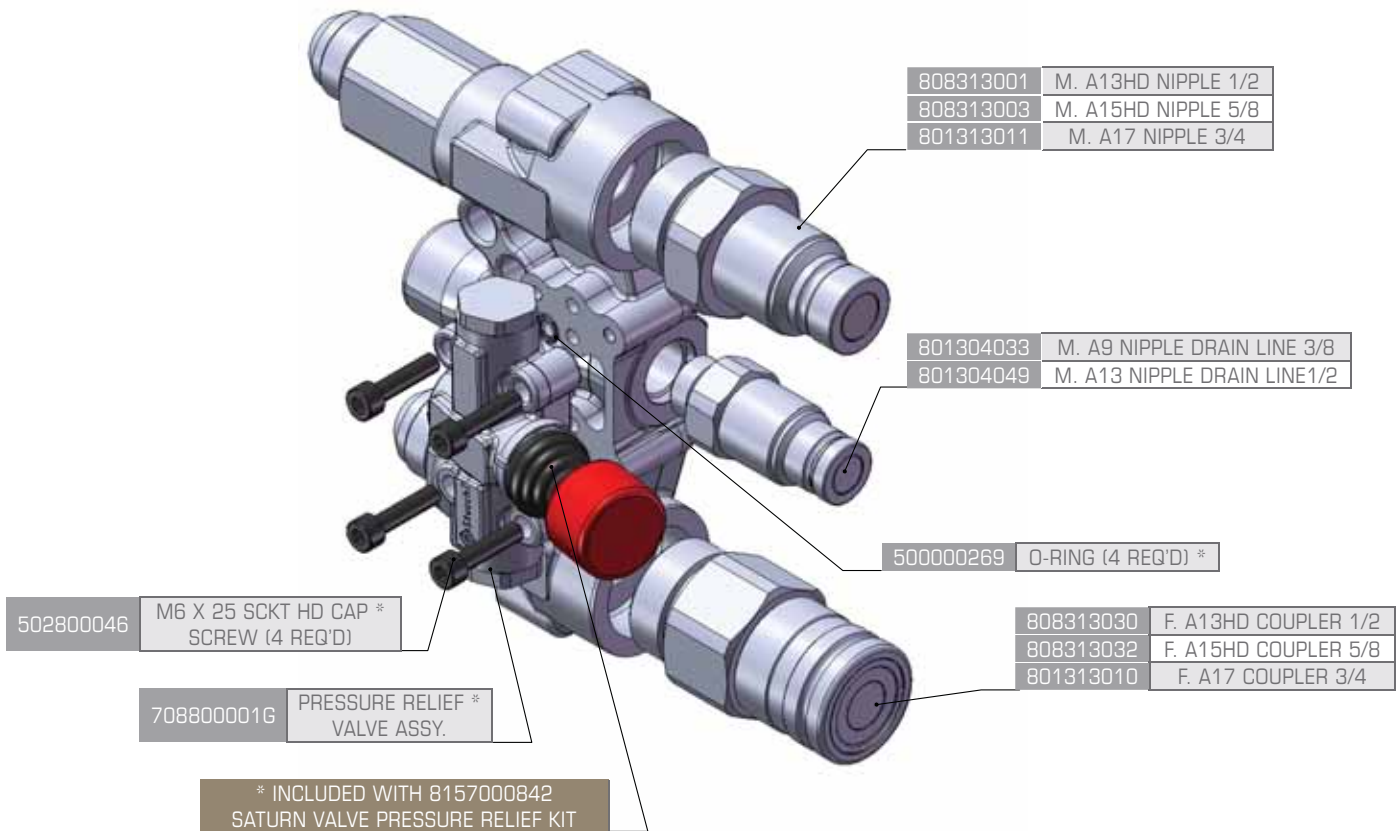

PART	ORDER CODE	DESCRIPTION
COUPLER	808313030	F. A13HD COUPLER
NIPPLE	808313001	M. A13HD NIPPLE
COUPLER	808313032	F. A15HD COUPLER
NIPPLE	808313003	M. A15HD NIPPLE
COUPLER	801313010	F. A17 COUPLER
NIPPLE	801313011	M. A17 NIPPLE
NIPPLE	801304033	M. A9 NIPPLE DRAIN LINE
NIPPLE	801304049	M. A13 NIPPLE DRAIN LINE
VALVE KIT	815700852	SATURN VALVE RELIEF KIT *

